



Colorado Department
of Public Health
and Environment

DEPARTMENT OF PUBLIC HEALTH AND ENVIRONMENT

Water Quality Control Division

5 CCR 1003-5

STATE BOARD OF HEALTH

REGULATIONS PERTAINING TO SWIMMING POOLS AND MINERAL BATHS

**Adopted 8/15/93, effective 9/30/93
Last amended 3/18/98, effective 4/30/98**

SWIMMING POOLS AND MINERAL BATHS

ARTICLE I

GENERAL

1.1 AUTHORITY:

Sections 25-5-801, 25-5-802, 25-5-803, 25-5-804, 25-5-805, 25-5-806, 25-5-807, 25-5-808, 25-5-809, 25-5-810 and 25-1-107, C.R.S. 1973, as amended.

Summary Closure:

When a bathing area is in such condition as to pose an imminent threat to the health of the public, the department shall order the bathing area to be closed until such time as the conditions are brought into compliance with minimum requirements. This action shall be taken by issuing an order in writing under the provisions of Section 25-1-107(m) or Section 25-1-506(c) Colorado Revised Statutes.

Article 1.2 Material Incorporated by Reference

These regulations incorporate by reference (as indicated within) material originally published elsewhere. Such incorporation does not include later amendments to or editions of the referenced material. Pursuant to Section 24-4-103 (12.5) CRS, the Department of Public Health and Environment maintains copies of the complete text of the incorporated materials for public inspection during regular business hours. Information regarding how the incorporated material may be obtained or examined is available from:

Information Center Librarian
Colorado Department of Public Health and Environment
Water Quality Control Division
4300 Cherry Creek Drive South, Building A
Denver CO 80246-1530.

Additionally, any material that has been incorporated by reference after July 1, 1994 may be examined at any state publication/depository library. Copies of the incorporated materials have been sent to the State Publications Depository and Distribution Center, and are available for inter-library loans.

1.3 DEFINITIONS: The following definitions shall apply in the interpretation and enforcement of this regulation. The word "shall" as used herein indicates a mandatory requirement.

1. "Abbreviations" (technical):

- A. "DE" means diatomaceous earth;
- B. "fps" means feet per second;
- C. "gpm" means gallons per minute;
- D. "mg/l" means milligrams per liter. When requirements in this regulation specify limits for liquid volume measurements using mg/l or

ppm, either may be used depending on the type of testing equipment available;

- E. "NSF" means National Sanitation Foundation;
 - F. ORP" means oxidation reduction potential;
 - G. "ppm" means parts per million. See notation under mg/l for use.
2. "Cross-Connection" means any physical arrangement whereby a potable water supply is connected, directly or indirectly, with any other water supply system, pool, sewer, drain, conduit, tank, plumbing fixture, or other device which contains, or may contain, contaminated water, sewage, or other waste, liquid or gas of unknown or unsafe quality which may be capable of imparting contamination or pollution to the potable water supply as a result of backflow.
Bypass arrangement, jumper connections, removable spools, swivel or changeover devices, four-way valve connections, and other temporary or permanent devices through which, or because of which, backflow could occur are considered to be cross-connections.
 3. "Department of Health" means the Colorado Department of Health and its duly authorized agents and employees.
 4. "Handhold" means a structure not over twelve inches above the water line around the perimeter of the pool wall, affording physical means for the bather to grasp the pool sides.
 5. "Instructional Program" means any pool activity which utilizes an instructor who is managing/controlling the activity (such as, but not limited to swim lessons, water aerobics, life saving class, scuba diving class, swim team practice and canoeing class).
 6. "Lifeguard Station" refers to the designated work station/area of a lifeguard.
 7. "Natural swimming area" means a designated portion of a natural or impounded body of water in which the designated portion is devoted to swimming, recreative bathing, or wading and for which an individual is charged a fee for the use of such area for such purposes. Appurtenances used in connection with the natural swimming area shall also be included.
 8. "Person" means individual, firm, partnership, association, corporation, company, governmental agency, club, or organization of any kind.
 9. "Plumb" means a line perpendicular to water surface and extending vertically to a point located at the front end of the diving board and at the center line directly in front of the diving board.
 10. "Pool" means swimming pool, wading pool, spray pool, spa or the like.
 11. "Private Pool" means any pool which is constructed in connection with or appurtenant to single family dwellings, condominiums or apartment houses, and which is used solely by the persons maintaining their residence within such.

12. "Public Bath" includes any mineral bath, bath house, public baths, and similar facilities which provide a contained water environment for immersion of the body, or provide a hot vapor environment for any purpose.
13. "Public Pool" means a pool that is not a private pool under definition 11, nor semi-public pool under Definition 17.
14. "Radius of curvature" means the radius arc denoting the curved surface from the point of departure from the springline (vertical sidewall) of the pool to the pool bottom.
15. "Remodeled" means an extension, enlargement, or modification of any public swimming area or related facility.
16. "Safety Ledge" means a subsurface slip resistant ledge attached to the side of the pool used as a foot hold.
17. "Semi-public pool" means a pool associated with hotels, motels, country clubs, health clubs and mobile home parks.
18. "Spa" or "Hot Tub" means a pool designed for relaxation, recreational, or therapeutical use where the user is sitting, reclining, or at rest and the pool is not drained, cleaned, or refilled for each user. The spa may include, but not be limited to, hydrojet circulation, hot water, cold water, mineral baths, or air induction bubbles or any combination.
19. "Spray pool" means a pool or artificially constructed depression for use by bathers in which water is sprayed, but is not allowed to pond, in the bottom of the pool.
20. "Superchlorination" means the periodic addition of sufficient amounts of an oxidizer to eliminate combined chlorine compounds (ammonia nitrogen or chloramine products) normally formed in pool or spa water.
21. "Swimming area" means a designated body of water of such volume and depth that one or more persons can swim in it and which is used for the purpose of swimming, recreative bathing, or wading and includes natural swimming areas and swimming pools.
22. "Swimming pool" means a body of water, other than a natural swimming area, maintained exclusively for swimming, recreative bathing, or wading and includes appurtenances used in connection with the swimming pool.
23. "Therapeutic Pool" means a pool used for physical therapy including but not limited to post-operative and pre-operative strength training, assistance of buoyancy of water, and other one-on-one training.
24. "Turnover rate" means the time necessary to circulate the entire volume of the pool water through the filtration system.
25. "Vertical" means a line perpendicular to the water surface that is not greater than 11 percent off plumb.

26. "Wading Pool" means any artificial pool of water equal to or less than 18" deep and intended for wading purposes.

ARTICLE II

SUBMISSION OF PLANS AND SPECIFICATIONS:

At least thirty (30) days prior to the construction, extension, enlarging, remodeling or modification of a public swimming area or related facilities, the plans and specifications complete with piping layout, equipment and mechanical specifications along with design calculations, shall be submitted for review and recommendations to the Colorado Department of Health which may direct that such plans and specifications be submitted to the municipality or other political subdivision in which the swimming area is or may be located rather than to the Department of Health. This section does not prohibit any municipality from requiring that the plans also be submitted to the proper authority of the municipality.

Public pool or semi-public pool facilities shall be built so as to conform to minimum design standards set forth in Article II below. The owner or his agent shall notify the Colorado Department of Health at the time of the beginning and completion of the pool to permit adequate inspection of the pool and related equipment. Upon completion of construction, a written certification from the public pool owner or his agent stating that the facility was built as approved must be submitted to the Colorado Department Health. The public pool or semi-public pool shall not be placed in use until all facilities necessary for compliance with the requirements of these regulations are installed and operable and approved by The Colorado Department of Health.

Professional service or creative work including consultation, investigation, evaluation planning, design surveying, and supervision of construction for the purpose of assuring compliance with these specifications and design requirements must be performed by a Registered Professional Engineer.

Request for review of plans and specifications form is included at the end of these regulations. The form must be completed and submitted with the plans and specifications.

ARTICLE III

DESIGN CRITERIA:

Public pools or semi-public pools built or remodeled after the effective date of these regulations shall conform to these minimum design criteria.

3.1 SURFACE, SHAPE, DESIGN, SLOPES:

Spas will be a maximum of four (4) feet deep. Wading pools will be a maximum of eighteen (18) inches deep in the center and twelve (12) inches at the sidewalls. The public pool shall be designed and constructed so that efficient and safe control of the area and bathers can be accomplished and so that the recirculation of water in the pool is not impeded. The slope of the bottom of any portion of the pool having a water depth of less than five (5) feet shall not be more than one (1) foot in twelve (12) feet and said slope shall be uniform.

In portions at the break where the shallow end (water five (5) feet deep or less) goes into to the deep end of the pool, the slope shall not exceed one (1) foot in three (3) feet. Walls of a pool shall

be either (a) vertical for water depths of at least six (6) feet or (b) vertical for a distance of three (3) feet below the water level below which the wall may curve to the bottom.

Depth markers shall be a minimum of four (4) inch numerals in a contrasting color on the deck, and four (4) inch numerals in a contrasting color on the vertical wall at or above water level. The dimensions of the pool in the diving area shall conform to the following table. (This drawing does not show shallow portions of pool.)

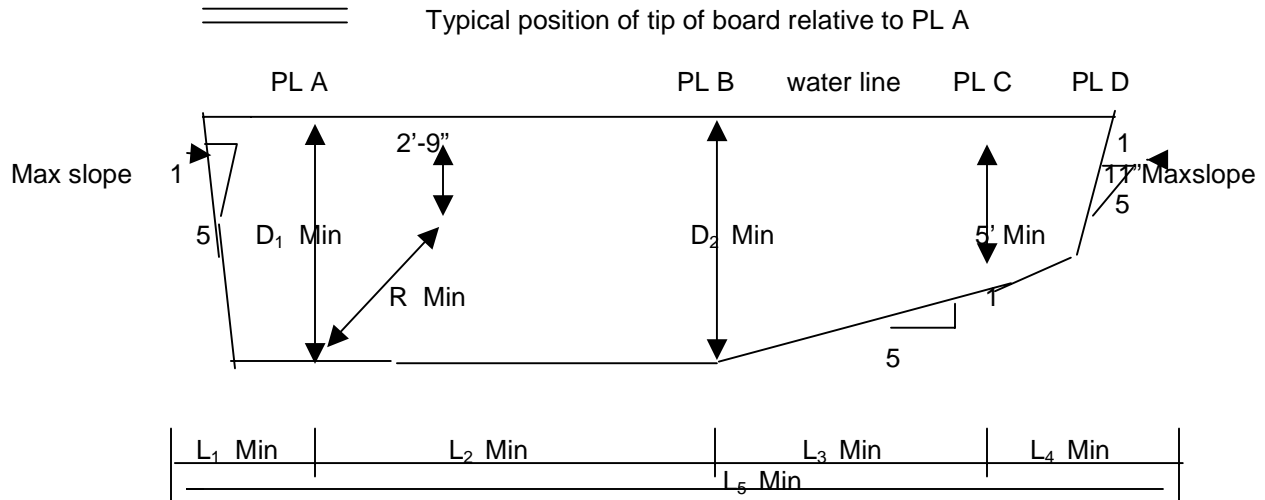

Note: L₄ is a minimum dimension to allow sufficient length opposite the board. This may of course be lengthened to form the shallow portion of the pool.

Related Diving Equipment		Minimum Dimensions								Minimum Width of Pool at		
Max Diving Board length	Max Board Height Over Water	D ₁	D ₂	R ₁	L ₁	L ₂	L ₃	L ₄	L ₅	PT.A	PT.B	PT.C
210'	26" (2/3 meter)	7'-0"	8'-6"	5'-6"	2'-6"	8'-0"	10'-6"	7'-0"	28'-0"	16'-0"	18'-0"	18'-0"
12'	30" (3/4 meter)	7'-6"	9'-0"	6'-0"	3'-0"	9'-0"	12'-0"	4'-0"	28'-0"	18'-0"	20'-0"	20'-0"
16' 1	1 meter	8'-6"	10'-0"	7'-0"	4'-0"	10'-0"	15'-0"	2'-0"	31'-0"	20'-0"	22'-0"	22'-0"
16' 3	3 meter	11'-0"	12'-0"	8'-6"	6'-0"	10'-6"	21'-0"	0	37'-6"	22'-0"	24'-0"	24'-0"

L₁, L₃, L₄ combined represent the minimum distance from the tip of board to pool wall opposite diving equipment.

At least fifteen (15) feet of free and unobstructed head room, including free from electrical wires and fixtures, shall be provided above diving boards. Horizontal separation of ten (10) feet shall be provided between the center line of diving boards and side walls except this may be reduced to eight (8) feet for surface boards less than 1/2 meter above water surface.

The minimum depth of water in areas dedicated for competitive events shall be four (4) feet. Attached wading areas shall be separated from the main pool(s) by a safety barrier or buoy line attached to the side walls. Separate wading pools shall be completely fenced with a three (3) foot high fence.

3.2 DECK AREAS:

The deck areas of all pools shall have a minimum of five (5) feet of unobstructed deck width measured from the water's edge. The deck area shall be impervious and easily cleanable and entirely surround the pool. Water will not be allowed to puddle or pond on the deck. The deck area shall have a slope of not less than 1/4 inch per foot and not more than 1/2 inch per foot directed to adequate drains or away from the pool. The deck shall have a non-slip finish. When deck drains are provided they should be so located that the deck drain will service not more than four hundred (400) square feet of the deck area. Deck drains shall be located not more than fifteen (15) feet on centers.

3.3 OVERFLOW GUTTERS:

The overflow gutter when provided, shall extend around the entire perimeter of the pool, except at steps or recessed ladders. The overflow gutter lip shall be level within .3 inch. This gutter shall be capable of continuously removing 100 percent of the recirculated water for return to the filter. All overflow gutters shall be connected to the recirculation system through a properly designed surge system. The causes produced from the maximum pool bathing load. Gutters shall be designed to prevent entrance or entrapment of bathers. The overflow outlets shall be provided with outlet pipes which shall in any case be at least two (2) inches in diameter. Outlets shall be a maximum of fifteen (15) feet apart and opening in grating less than 1.5 times cross-sectional pipe area.

3.4 SKIMMERS:

All skimmers, when provided, shall comply in all respects with the NSF standards. At least one skimmer shall be provided for each 400 square feet of water surface or fraction thereof, with a minimum of two skimmers on opposite sides and at opposite ends. The skimmers shall be capable of continuously removing 100 percent of the designed turnover rate. The skimmers shall be built into the pool wall. The skimmers shall be adjustable and shall operate freely with continuous action to variations in water level over a range of at least four (4) inches.

All parts of the skimmer must be in place and in good operating condition. An easily removable and cleanable, properly fitting basket or screen shall be provided, through which all overflow water must pass to trap trash and debris with deck top access to facilitate cleaning. Each skimmer shall be provided with an equalizer line and skimmer equalizer line check valves. The equalizer pipe shall provide an adequate amount of water for pump suction should the water of the pool drop below the weir level. Weirs and float valves must be in place and in proper working condition. If any other device, surge tank or arrangement is used, a sufficient amount of water for pump suction shall be assured.

3.5 INLETS:

Pool inlets shall be submerged a minimum of twelve (12) inches below the water surface and located to produce uniform water and chemical circulation throughout the pool with a maximum interval of fifteen (15) feet on walls. Wall and floor inlets shall have adjustable orifices; and if side wall inlets are used, they must have adjustable directional flow capability. Stainless steel gutters are exempt but must meet manufacturers specifications.

Floor inlets shall be placed at fifteen (15) foot intervals, and the distance from floor inlets to wall shall not exceed fifteen (15) feet.

3.6 MAINDRAINS:

All pools shall be provided with a minimum of two maindrains, connected to a common line and evenly spaced at the deepest point to facilitate proper bottom circulation and permit the pool to be completely and easily emptied. Each maindrain must have the capacity to handle 100 percent of designed turnover rate. Maindrains shall be covered by proper grating which is secured. Openings of the grating shall be at least four (4) times the area of the suction line. No direct connections to sewers shall be permitted.

3.7 STEPS, LADDERS, DIVING PLATFORMS AND DIVING TOWERS:

Steps or ladders shall be provided at the shallow end of the pool if the vertical distance from the bottom of the pool to the deck or walk is over two (2) feet. Recessed steps or ladders shall be provided at the deep portion of the pool and if the pool is over thirty (30) feet wide, such steps or ladders shall be installed on each side. Ladders shall be located so that divers need not turn back to reach them. Stairs leading into the pool shall be of non-slip design, have a minimum of tread width (12) inches and a maximum height of ten (10) inches. A minimum of one handrail shall be required at the stairs leading into the shallow end. The stairs shall have a two (2) inch wide contrasting color tread edge, and shall be clearly visible to the user.

There shall be a clearance of not more than five (5) inches nor less than three (3) inches between any ladder and the pool wall. Ladders shall have non slip treads. If steps are inserted in the wall or if stepholes are provided, they shall be of such design that they may be cleaned readily and shall be arranged to drain into the pool to prevent the accumulation of dirt therein. Stepholes shall have a minimum tread depth of five (5) inches. Where stepholes and ladders are provided within the pool, there shall be a handrail at the top of both sides thereof, extending over for the edge of the coping or the edge of the deck. Stepholes shall have a contrasting color to the wall in which they are placed. Supports, platforms and steps for diving boards/towers shall be of substantial construction and of sufficient structural strength to safely carry the maximum anticipated loads. Steps shall be of corrosion-resistant material and of non-slip design. Handrails shall be provided at all steps and ladders leading to diving boards more than 1/2 meter above the water. Platforms and diving boards more than 1/2 meter high shall be protected with guard railings.

Starting blocks must be structurally sound and secured in place. Starting blocks must be removable. Maximum height of starting blocks over water less than four (4) feet deep is eighteen (18) inches above the water surface. Starting blocks shall be clearly labeled, "NO DIVING."

3.8 HOSE BIBBS:

A sufficient number of hose bibbs with hose bibb vacuum breaker backflow preventers for cleaning the deck areas shall be provided. These hose bibbs shall be placed to allow the proper cleaning of entire deck with a maximum hose length of fifty (50) feet. Water pressure shall be sufficient to provide effective cleaning and shall not effect the water pressure in other parts of the building or the appurtenances serving the pool.

3.9 SUCTION CLEANER:

Equipment shall be provided to remove sediment, sludge and other accumulations from the bottom of the pool. The pool shall be provided with adequate suction to operate the cleaning device. Adequate suction is defined as the ability to sufficiently remove all normal accumulations from the pool bottom. Vacuum pipes shall be at least 1 1/2 inches in diameter and vacuum hoses shall have a diameter of at least 1 1/2 inches.

3.10 EQUIPMENT ROOMS/RECIRCULATION SYSTEMS/APPURTENANCES:

The recirculation system shall consist of pumping equipment, hair and lint baskets, filters, flowmeters, valves, backflow preventers, and gauges, together with all necessary pipe connections to the inlets and outlets of the pool and means for backwashing filters. All of the above mentioned equipment shall be in good working order. Disinfection equipment, with the exception of chlorine gas may be housed in the equipment room. The entire system and all of its component parts shall be capable of producing a minimum of a six (6) hour turnover in all pools with the exception of spas and wading pools. Wading pools shall have a minimum turnover rate of one (1) hour and spas shall have a minimum turnover rate of 1/2 hour. If the pump is located above the overflow level of the pool, the pump shall be self-priming. Pumps shall be capable of supplying the required recirculation rate at the maximum total dynamic head attained during operation. The hair/lint basket shall be installed on the suction side of the pump when the pump precedes the filter. The hair/lint basket shall have the following design features:

1. Water shall pass through the basket from the inside to the outside.
2. The basket shall be constructed of corrosion resistant material.
3. The area of the basket openings shall be at least ten (10) times the area of the inlet pipe into the basket.
4. The width or the diameter of the basket mesh openings shall not be more than 1/8 inch.
5. A removable basket with perforated openings shall be provided unless sufficient cause can be shown for using some other type.
6. Two appropriate baskets, one in use and one spare, shall be on hand for each hair/lint pot.

The recirculation system shall be installed in accordance to all manufacturers specifications.

3.11 DISINFECTANT AND CHEMICAL FEEDERS:

All chemical feeders shall comply in all respects with the standards of the NSF covering such equipment. Feeders shall be of sturdy construction and materials which will withstand wear, corrosion or attack by the solutions being fed. Feeders shall have a graduated and clearly marked dosage adjustment to provide flows from full capacity to 25 percent of such capacity. The device shall be capable of continuous delivery within 10 percent of the dosage at any setting and shall be capable of supplying dosages at the rates needed to provide the residuals required by these regulations and standards. The feeder shall incorporate failure proof features, so the chemicals/disinfectant cannot feed directly into the pool, water supply or the pool enclosure under any type of failure of the equipment or its maintenance. The feeder shall be capable of supplying at least the minimum equivalent of one (1) pound of chlorine per twenty-four (24) hours for each ten thousand (10,000) gallons of pool capacity under conditions of maximum load. All chemicals shall be introduced downstream from the heater.

Owners applying chemicals for controlling pH through chemical feed equipment shall provide equipment with:

1. Adequate size and design to allow routine cleaning and maintenance;
2. Material resistant to chemical action;
3. Means for automatic shut off when pool flow is interrupted;
4. Means for automatic or mechanical chemical feed equipment for pH control shall be used on all pools of fifty thousand (50,000) gals volume or greater;
5. Any pool feeding caustic soda (NaOH), carbon dioxide (CO₂), or Department of Health approved disinfectants shall be automated, metered and controlled as directed by the manufacturer and the Department of Health.

3.12 SAND FILTERS:

All sand filters shall comply in all respects with the standards of the NSF covering such filters. Sand filters shall be properly sized to achieve the proper turnover rate without exceeding the maximum flow rate for the filter design. Rapid sand filters shall be sized for a filter rate not to exceed 3-5 gal./min./sq.ft. The underdrain system shall be of corrosion resistant and durable material so designed and of such material that the orifices or other openings will maintain an approximate constant area. It shall be designed to provide even collection or distribution of the flow during filtration and backwashing. The filter system shall be provided with a rate of flow indicator, a method of air release of the filter tank, and pressure gauges, all in good operating condition. A backwash sight glass shall be provided. The recommended sand specifications must be provided with each filter on a plate on the filter tank in an easily readable location. Backwash lines shall not be restricted in any way between the filter and the sanitary sewer.

3.13 DIATOMEACEOUS EARTH FILTERS:

All diatomeaceous earth (DE) filters, whether of the vacuum or pressure type, shall comply in all respects with the standards of the NSF covering such filters. Rate of filtration: The filter area shall be such that the rate of filtration shall not be greater than 1.5 gpm/sq.ft. or that specified by

the NSF for the specific filter in use to achieve the proper turnover rate for the pool. Where DE body feed is provided, the device shall be accurate within 10 percent, and shall be dependable. The filter and all component parts shall be of such materials, design and construction to withstand normal continuous use without significant deformation, deterioration, corrosion or wear which could adversely effect filter operation. The filter shall be so designed and constructed to eliminate the possibility of introduction of the DE into the pool. The filter plant shall be provided with such pressure, vacuum or compound gauges as are required to indicate the condition of the filter. All filters shall be equipped for cleaning. Provisions shall be made to completely and rapidly drain the filter. A rate of flow indicator shall be provided on the filter system. Backwash lines shall not be restricted in any way between the filter and the sanitary sewer.

3.14 CARTRIDGE FILTERS:

Cartridge filters must meet NSF standards. Maximum flow rate is .375 gpm/F². Air relief valve pressure gauges must be in place and in good operating condition. There must be no filter by-pass of any kind.

3.15 MAKE-UP WATER FACILITIES AND CROSS CONNECTIONS:

All potable pool makeup water shall be introduced through a reduced pressure principle backflow preventer (RP) accepted by the Colorado Department of Health, Water Quality Control Division or fill spout with an air gap at least twice the diameter of the fill pipe. The pool fill spout shall be located under a low diving board or adjacent to a handrail and not extrude past the edge of the pool more than 1- 1/2 times the diameter of the pipe. Water pressure shall be such so as to allow the fill line to operate at full valving and not interfere with water pressure in the other parts of the facility. All other accessories to the recirculation system, such as chemical solution feeders and water fed chlorinators shall be protected against backflow into the water supply system by installation of an approved reduced pressure principle backflow preventer. The backflow preventer must be tested on installation and at least annually thereafter by a certified cross-connection control technician.

3.16 PIPING SYSTEM:

The piping system shall be so designed to reduce friction losses to a minimum with maximum flowrate. The maximum rate of flow in suction plumbing shall not exceed 7 feet per second. The maximum rate of flow in return plumbing shall not exceed 10 feet per second. Flanged joints or unions shall be inserted at intervals to permit any part of the system to be taken down for cleaning or repairs. The piping system of the pool shall be labeled and color coded to identify filtered water, raw water, wastewater, vacuum cleaning lines and heating lines. The color code shall be as follows:

Raw Water	Yellow
Filtered Water	Green
Wastewater	Black
Heated Water	Red
Vacuum Cleaning Lines	Blue

A vacuum gauge shall be installed in the suction line prior to the pump. A flow meter shall be provided to measure the total flow of the system. Flow meters shall be placed on a pipe length of no less than eight (8) feet and away from elbows and other flow restrictive equipment in accordance to manufacturer's specifications. Directional flow arrows shall be in place on all lines. A complete schematic diagram of the entire pool system shall be in place in the mechanical room and be of such size and design as to be easily read. It shall be of such construction so as to remain in good condition and readable at all times. The schematic shall include a valve legend, pump schedule and complete operating instructions for the entire system.

3.17 EMERGENCY SHUTDOWN CONTROL:

An emergency shutdown station shall be provided at a place that is relatively convenient to the lifeguards, yet secured from the public. This station shall disable all pool circulation, mechanical, chemical feed and electrical devices and must be accessible to a standing adult.

3.18 MECHANICAL ROOM:

This room will provide a (2) two foot minimum clearance and/or in accordance to manufacturers specifications around all pool mechanical and recirculation equipment to allow access for servicing and repairs. The room shall be located in such a manner that it may not be entered from the shower rooms or from the pool area by unauthorized persons. The floors shall have a minimum slope of 1/4 inch per foot toward the drains. The floor drains shall be of such number and placement so as to ensure a dry floor at all times. The drains from the mechanical equipment room shall not discharge to a sewer or drain which may overload. Miscellaneous equipment, chemicals, and appurtenances shall not be stored in the pool mechanical equipment room.

3.19 LIGHTING ELECTRICAL REQUIREMENTS:

All pools constructed with underwater lighting shall have not less than 500W/1000 sq.ft. of pool surface area. All indoor pools and all outdoor pools operated at night shall have artificial lighting sufficient to permit the maindrains to be clearly visible, at all times. Such lights shall be spaced to provide illumination so that all portions of the pool may be readily seen without glare. Area lighting shall provide at least 0.6 W per square foot of deck area and/or surrounding area within the enclosure around the pool. If such light is used for night swimming, area and pool lighting combined shall provide at least 10-foot candles of illumination per square foot of pool area. Ground fault interrupters shall be provided for all lights and electrical outlets of the pool complex, including dressing rooms and mechanical equipment rooms. All electrical wiring shall conform with the current National Electrical code of the National Underwriters Laboratory or equivalent. No overhead electrical wiring shall pass within 20 feet of the pool enclosure.

3.20 DRESSING ROOMS:

The dressing rooms shall be located adjacent to the locker or checkroom and showers. The layout of the dressing rooms for the exclusive use of swimmers shall be such that the bathers, on leaving the dressing room, shall pass the toilets and showers enroute to the swimming pool.

Dressing rooms, toilet facilities and shower rooms are required for all pools except those provided in connection with lodging facilities where the pool is not available to the public not occupying

such facilities (hotels, motels, mobile home parks, campgrounds) and shall be handicapped accessible.

Floors of toilet and shower rooms shall have a minimum slope of one-fourth (1/4) inch per foot to the drains.

Floors of toilet, shower rooms and dressing rooms shall be of smooth non-slip finish and shall be impervious to moisture. No carpeting is permitted.

Hose bibbs of three-fourths (3/4) inch minimum size and served by not less than three-fourths (3/4) inch pipe shall be provided to enable the entire toilet and shower room to be conveniently flushed by hose.

The material used for walls, partitions, and furniture shall be such that it can be easily cleaned and will not be damaged by frequent hosing, wetting, or disinfection.

Dressing rooms to be used simultaneously by both males and females shall be divided into two parts separated by a tight solid partition, with no openings; each part shall be designed for males or females. The entrances and exits shall be screened to break line of sight.

3.21 TOILETS:

Toilet facilities shall be provided for both males and females and shall be accessible to disabled persons.

Flush water closets with elongated bowls, and urinals shall be provided and shall be kept clean and properly maintained. The ratio of water closets shall be one (1) closet and one (1) urinal for each sixty (60) men and one (1) water closet for each forty (40) women expected at the time of maximum load. All fixtures shall be properly protected against back siphonage. Partitions, walls and ceilings shall be constructed of material not adversely affected by steam, water, or disinfectants. Toilet rooms shall be ventilated so that no odor nuisance can exist.

3.22 SHOWER FACILITIES:

Separate shower facilities shall be provided for males and females shall be accessible to disabled persons, and, when provided for the exclusive use of swimmers, shall be so located that bathers must pass through the shower room before entering into the swimming pool area. The minimum number of showers provided shall be in proportion of one (1) to each forty (40) bathers expected at the time of maximum load. The ceilings and walls of the shower room or area shall be constructed of smooth, impervious, easily cleanable material, not adversely affected by steam or water. The floors of the shower room or area shall be constructed of non-slip, impervious, easily cleanable material, not adversely affected by steam or water.

Showers shall be supplied with water at a temperature of at least 90 F with a minimum rate of three (3) gallons of water per shower per minute. Thermostatic tempering, or mixing valves shall be installed if necessary to prevent scalding of bathers.

Where shower booths are provided in the shower room, the booth partitions shall be of a material which will not be damaged by shower water and shall have a minimum clearance of six (6) inches

above the floor. Shower rooms shall be provided with at least ten (10) foot candles of light upon all surfaces so that all parts are visible for easy cleaning.

3.23 SWIMMER LOAD (See **NOTE***)

Maximum swimmer loading shall be determined by the following standards:

- a. Diving area: A maximum of two (2) persons permitted for the area within a ten (10) foot radius of any diving board or platform.
- b. Swimming area: One person for each twenty four (24) square feet of pool. This zone is that part of the pool that is deeper than three and one half (3 ½) feet.
- c. Non-swimming area: ten (10) square feet of pool required for each person in that part of the pool less than three and one half (3 ½) feet.

3.24 FENCING:

Every swimming pool in a non-restricted public place shall be fenced to prevent unauthorized access to the pool except through controlled entrances. A building or structure can serve as a fence or barrier. Fencing shall be a minimum of sixty inches (60") high, and shall have self-closing, self-latching gates, with the latch a minimum of fifty four (54) inches high. Wrought iron fence picket spacing shall not be greater than four (4) inches. Entrances shall be handicapped accessible. Local building codes or ordinances shall preempt this requirement, provided that said codes or ordinances are more stringent than the requirements in this section.

* **NOTE:** Section 3.23, SWIMMER LOAD, is included for guidance; however, Section 3.23 is not part of the official Regulations pertaining to Swimming Pools and Mineral Baths as published in the Code of Colorado Regulations (5 CCR 1003-5). Although Section 3.23 was included in the revised Regulations pertaining to Swimming Pools and Mineral Baths that were adopted by the State Board of Health on August 18, 1993, it was inadvertently omitted from the revisions that were submitted to the Secretary of State for publication in the Code of Colorado Regulations (CCR), and therefore, was not published as part of the official rules. The Board submitted a request to the Attorney General's Office to determine that the omission was the result of a clerical error and to allow submission of Section 3.23 for publication in the CCR. However, the Attorney General's Office determined that the requested change is substantive rather than procedural; hence, a new rulemaking is necessary to properly promulgate the omitted rule.

Section 3.23 is an important section as it provides the formulas for determining maximum swimmer load. Swimmer load is an important parameter used in determining pool operational and maintenance procedures. Therefore, section 3.23 is included for reference in this unofficial version of the regulations published by the Department. The Board of Health will consider re-adoption of the omitted rule during a future rule-making proceeding.

ARTICLE IV

SANITARY STANDARDS: All public and semi-public pools shall conform to these minimum standards.

4.1 DISINFECTION

1. Disinfection Equipment General:

- A. All pools shall be provided with an automatic or mechanical means of adding a disinfectant to the swimming pool water. Manual addition of chemicals or chemical solutions will be allowed only under special or emergency conditions which require that the pool be closed. During such condition, the pool must remain closed at least one pool turnover or until such time as the chemical is thoroughly dispersed throughout the pool water. After hand treatment for breakpoint disinfection and algae prevention, use of the pool may be resumed when the free disinfectant level drops within the range specified in Table 1, Section 4.7.
- B. General Requirements (Disinfection Equipment): Chemical feeder equipment shall comply with all of the following:
1. Equipment shall be capable of being easily disassembled for cleaning and repair.
 2. Equipment shall be constructed of corrosion-resistant materials.
 3. Equipment shall be constructed to permit repeat adjustments without loss of output rate accuracy.
 4. Equipment shall be constructed to minimize a stoppage from debris, chemicals intended to be used therein and/or from foreign materials that may be contained in said chemicals.
 5. Equipment shall be designed specifically for the type of disinfectant to be used.
 6. Equipment shall be provided with controls for adjusting rate of flow of disinfectant.
 7. Equipment shall conform to the National Sanitation Foundation, (Standard 50) Swimming Pools, Spas, and Hot Tubs Circulation System Components, February 1, 1993.
 8. Y strainers shall be installed in the disinfectant feeder supply line.
 9. No connection shall be made to an external water supply for disinfection system operation.
- C. Disinfection Point of Application: The application point of disinfectant shall be located in the return line downstream of the filter, recirculation pump, heater, and

and flow meter.

2. Chlorine Gas Equipment:

- A. All chlorine gas equipment must comply with Section 4.1(1)(A&B).
- B. Housing: A dedicated, well ventilated house or room at ground level shall be provided exclusively for chlorine gas purposes. The lockable door shall have a foot square "one-light" shatterproof and gas tight window to allow observation of conditions in the room prior to entering. The door shall not open to the swimming pool or deck and shall open to the outside. The door of the chlorine room shall have "panic hardware." The house or room shall be located so that chlorine gas, if accidentally released, will not flow into the pool area, mechanical room, or into the building ventilation. (i.e., opposite side of pool from the direction of prevailing winds)
- C. Exhaust Ventilation: Sufficient ventilation shall be provided to allow one complete air change in the chlorination room every minute. The air exhaust duct shall be located within six (6) inches of the floor level. A louvered fresh air intake shall be provided near the ceiling to serve as a make-up air supply when the exhaust fan is operating. The exhaust fan shall be wired to a control switch which is located outside and adjacent to the chlorine room door. The exhaust ducting shall terminate a point not less than 8 (eight) feet above surrounding grade. Exhaust duct termination point shall be outside of the building, away from any occupied area or any fresh air intake.
- D. Lighting: A minimum of 10 (ten) foot candles of illumination shall be provided and electrical switches for control of the lighting shall be located on the outside and adjacent to the chlorine room door.
- E. Chlorine Feeder Seals: A new washer or gasket approved for use on chlorine gas shall be used each time a chlorine cylinder is connected to the chlorinator. Spare washers/gaskets shall be kept on site.
- F. Vent Line: The vent line, exhaust duct and/or pressure relief valve from the gas chlorinator and/or occupied area or any fresh air intake.
- G. Leakage Test Kit: A leakage test kit consisting of ammonia (26⁰ Baume) water and shall be provided.
- H. Respiratory Protection Equipment: At least one Self-Contained Breathing Apparatus (SCBA) minimum thirty (30) minute capacity certified by the National Institute for Occupational Safety and Health (NIOSH)--shall be provided, operative and hung in a conspicuous place outside the chlorination room in an area easily accessible to pool employees. A cabinet may be utilized to provide security for the SCBA. Monthly working condition checks of the SCBA shall be done and records kept thereto. Pool employees shall be trained in the proper use of SCBA equipment.

- I. Chlorine Cylinders: Chlorine cylinders shall be anchored in an upright position to prevent falling over. A valve stem wrench shall be maintained on any cylinder in use, so the supply can be shut off quickly in case of an emergency. The valve protection hood shall be kept in place, except when the cylinder is connected to the feeder. Empty chlorine gas cylinders shall be tagged as such. Full and empty chlorine gas cylinders shall be stored only in the chlorine room.
- J. Platform Scales: Platform scales for chlorine cylinder(s) shall be provided for cylinder(s) in use. Said scales shall be capable of indicating gross weight within one half (1/2) pound accuracy.
- K. The chlorinator shall be a solution-feed type, capable of delivering chlorine at its maximum rate without releasing chlorine gas to the atmosphere.
- L. The chlorinators shall be designed to prevent the backflow of water into the chlorine regulator.
- M. The gas chlorine room shall have a Hazardous Materials classification sign affixed to the entry door. This sign shall use the National Fire Protection Association Hazard Rating System as shown below specific for gas chlorine.

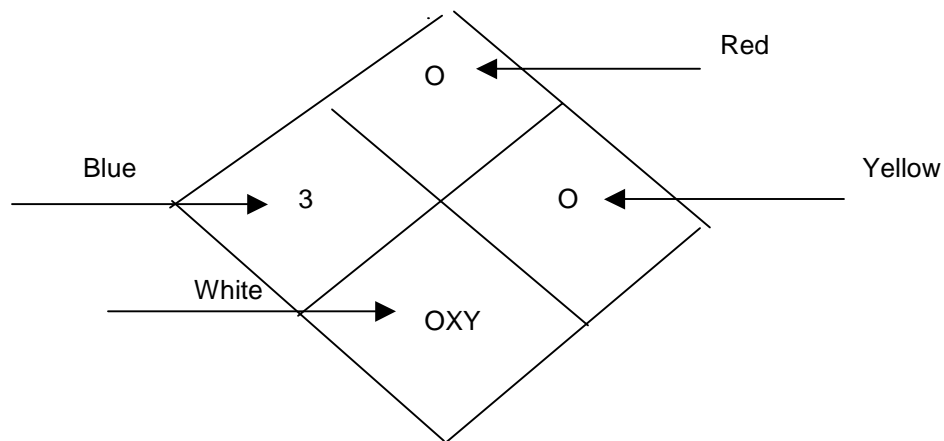

- N. The recirculatory pump and chlorine booster pump motor controls shall be interlocked so that the booster pump cannot operate when the recirculating pump is off or during the back wash cycle.
3. Chlorinated Hypochlorites and Chlorinated Isocyanurates:
- A. All hypochlorite and Chlorinated Isocyanurate dispensing equipment shall comply with Section 4.1.(1)(A&B).

- B. When a hypochlorite solution is used, it shall be fed through hypochlorinator equipment. Such equipment shall also provide the following additional features:
- (1) Positive feed under all conditions of pressure in the circulating system, without artificial constriction of the pump suction line, whether this line is under vacuum or pressure.
 - (2) Regulation to insure constant feed with varying supply of back pressure.
 - (3) Positive features to prevent backflow from recirculation system to the solution container and provision for reducing to a minimum the entry into swimming pool of free calcium released from calcium hypochlorite.
 - (4) Provision to prevent siphoning of hypochlorite solution when the recirculation pump and hypochlorinator are both turned off. (This applies to above swimming pool level installations only.)
- C. Pools using Chlorinated Isocyanurate or Chlorinated Hypochlorites shall have onsite and available either a Self-Contained Breathing Apparatus as required in Section 4.1(2)(H) or have available a canister type respirator approved by either the U.S. Bureau of Mines or NIOSH for use with chlorine. Canister type respirators must have available canisters which have not exceeded their manufactures expiration date. Canister dates should be checked monthly and recorded on the record. This respiratory protection device shall be stored outside the chlorine area, be kept in good working order, and be easily accessible to the employee.

4. Bromine:

Bromination equipment, if employed, shall meet the provision of Section 4.7.

5. Other Disinfectant Equipment and Methods:

Other disinfecting equipment or materials may be used if they have been adequately demonstrated to the Colorado Department of Health and/or its authorized agent to provide a satisfactory residual effect which is easily measured or where demonstration and analysis provide assurance that results are effective under conditions of use to meet the water quality standards set forth in these regulations and not be dangerous to public health, create objectionable physiological effects, or impart toxic properties to the water.

6. Storage and Handling of Chemicals:

- A. All chemicals shall be kept out of reach of children.
- B. Chemicals shall be stored in original containers; with the original lids securely in place; out of the sunlight; in a cool, dry, well ventilated area. Chemicals supplied in bulk bag form shall be stored in clearly marked corrosive resistant containers with tightly fitted lids.

- C. Chemicals shall not be stored near a heat source, open flame, or electrical equipment.
- D. Sanitizers or oxidizers shall not be stored in the same area as pool equipment.
- E. Liquid chemicals shall not be stored above or adjacent to dry chemicals.
- F. Pool chemicals shall not be stored in the same area as insecticides, herbicides, fertilizers or liquid petroleum products.
- G. Chemicals shall not be stored above eye level.
- H. Shelving used for chemical storage shall be secure.
- I. Acids shall be stored separately from all bases.
- J. Chemicals packaged in absorbent containers shall be kept at least six (6) inches off the floor on nonflammable surfaces.
- K. All chemical storage areas shall be kept clean.
- L. Manufactures label instruction shall be complied with.
- M. Separate measuring devices for each chemical shall be used. These measuring devices shall be clean, dry and constructed of material compatible with the chemical to be measured. Glass shall not be used.
- N. Chemicals shall be added to water, water shall never be added to chemicals.
- O. Oxidizers shall not be mixed with any other chemicals.
- P. Chemicals shall not be mixed with powdered chlorine or liquid chlorine.
- Q. Smoking, eating, or drinking shall not be allowed when using chemicals.
- R. Disposal of chemicals and/or empty containers shall be in accordance with label instructions.

4.2 EQUIPMENT AND PERSONNEL: (Rule 4.2 (adopted 5/17/95) was not extended by SB 96-236 and therefore expired May 15, 1996)

4.3 SWIMMING POOL WATER SUPPLY:

1. The potable water supply serving the swimming pool, plumbing fixtures, drinking fountains, showers, and other water using devices shall be in compliance with the minimum sanitary standards for drinking water as set forth in the Colorado Primary Drinking Water Regulations, 5 C.C.R. 1003-1.

2. The potable water supply shall be delivered at a sufficient rate to enable the swimming pool and all other water using devices to be operated satisfactorily.
3. There shall be no unprotected cross-connections between the potable water supply and the swimming pool recirculation piping.

4.4 WATER TESTING EQUIPMENT:

Every swimming pool shall be provided with water testing equipment for the following determinations:

1. A test-kit for determining the hydrogen ion concentration in the pH range of six and eight-tenths (6.8) to eight (8.0).
2. A test-kit for determining the residuals of the disinfectants in current use. This test kit must encompass the minimum to maximum range denoted in Table 1, Section 4.7.
3. A test-kit for determination of total alkalinity.
4. A test-kit for the determination of the cyanuric acid concentration if said chemical is being used as a chlorine stabilizer.
5. A test-kit for determination of calcium hardness.
6. A hand thermometer accurate to +2 F shall be available to check the temperature of the water in the pool itself.

All test-kits must have reagents that are not outdated. Other testing equipment may be required by the Colorado Department of Health with changing technology or use of other specific methods of disinfection.

4.5 BACTERIAL QUALITY:

1. The bacterial quality of the water in pools shall not have a fecal coliform density in excess of one per 100 ml at any time.
2. Any water sample obtained from pools shall not contain more than 200 bacteria per milliliter, as determined by the Standard (35 degrees Celsius) Plate Count, per the 18th edition of Standard and Wastewater (1992).
3. The water samples used in any bacterial analysis will be examined using the procedures outlined in the 18th edition of Standard Methods for the Examination of Water and Wastewater (1992).
4. Should any two consecutive water samples taken from pools exceed the bacterial standards in "1" and/or "2" above, the facility shall be immediately closed until the bacterial quality of the water is within the required parameters.

4.6 WATER QUALITY STANDARDS FOR NATURAL SWIMMING AREAS:

- 1) Natural swimming areas are required to meet the following bacteriological quality:
 - A. Maximum contaminant level is:
 - 1) 235 Escherichia coli per 100 ml sample (see appendix B).
 - B. Natural swimming areas shall take bacteriological samples at a minimum of once every seven (7) days and no less than five (5) times in a calendar month during use periods. At least one time per calendar month, natural swim areas shall take bacteriological samples at least 24 hours prior to the beginning of a peak-use period and within 24 hours after the end of the same peak use period. Timely response to water quality problems require that the results of this sampling must be known within 3 days of the sampling.
 - C. If several bacteriological samples are taken in one day, those parts of the natural swimming area with results exceeding the maximum contaminant levels listed in (A) above must be closed to the public.
 - D. Except as provided in subsection E, a natural swimming area shall be closed immediately upon receipt of any sampling result which indicates that the E. coli density exceeds 235 organisms per 100 ml.
 - E. Owners/operators of natural swimming areas that have entered into a memorandum of agreement with the Colorado Department of Public Health and Environment pursuant to this subsection, and that are operating in full compliance with such agreement, shall close all natural swimming areas immediately up on receipt of sampling information which indicates that the results of a second sample for E. coli density exceed 235 organisms per 100 ml. Where the second sample is taken from the same location and within 2 hours of receiving an initial sampling result for E. coli density exceed 235 organisms per 100 ml, and shall close all natural swimming areas where the result of any single sample for E. coli density exceeds 576 organisms per 100 ml. When the E. coli level in the initial sample exceeds 235 organisms per 100 ml, a notice must be posted at the natural swimming area warning swimmers of the presence of elevated levels of bacteria (see appendix C). Entering the Memorandum of Agreement is voluntary, however, such memorandums of agreement shall contain provisions that require the following:
 1. Daily completion of a Data Log Form that records all observable information relevant to potential E. coli impacts to the specific swimming area
 2. Personnel on site, during all times the natural swimming area is open to the public responsible for observing and recording such relevant information.

3. E. coli sampling at the natural swimming identified occurrences that are likely to increase the E. coli level above the 235 organisms per 100 ml. Such occurrences shall be defined in the MOA.
 4. Delivery of all samples to a Department approved laboratory within six hours of taking the sample, for initiation of analysis the same day as delivery. Results must be received the following day;
 5. Protocols for control samples;
 6. Such other provisions as the parties of the MOA determine to be necessary to predict, to prevent, and to control levels of E. coli in excess of 235 organisms per 100 ml.;
 7. The parties of the MOA may revise or eliminate terms and conditions required by this subsection to be included in any MOA, where the parties of the agreement determine that the required term or condition is not providing relevant or necessary information for the protection of public health. Either party to the MOA may cancel the MOA by providing written notification 30 days in advance.
- F. The first sample of the swimming season shall be taken at least 5 days prior to opening the area.

Failure to meet any of these requirements shall constitute grounds for closure of the natural swimming area and must be reported to this department or its designated agent by telephone call or FAX, as soon as possible but no later than 24 hours after determination. Signs must be posted to inform the public of such closure at the access to the area.

- 2) The natural swimming area may re-open when (see appendix B or C):
 - A. The sample result shows that the level of Escherichia coli is less than 235 per 100 ml sample.
 - B. Samples must be taken at the same location as the original(s), if more than one sample is taken on any day, the highest result must be used for compliance purposes.
- 3) The samples shall be taken (see appendix D):
 - A. In the area of the greatest bather load or activity,
 - B. During regular business hours,
 - C. Where the water depth is approximately 3 feet,
 - D. From within approximately 12 inches of the surface,
 - E. By an individual trained in proper sampling techniques.

All samples taken shall be examined in accordance with the 19th edition of Standard Methods for The Examination of Water and Wastewater (1995), Parts 9221 A, C, E; 9222 A, D, E; 9211B; 9212 B; 9213 D; 9221 F; 9223 A, B: and 9020 or by other method accepted by the Colorado Dept. of Public and Environment. Records of all sampling results must be maintained at the facility for a period of three (3) years. All bacteriological sampling results taken in any month must be submitted to this department or its designated agent by the 15th of the following month.

- 4) Each natural swimming area shall have an approved management plan at each facility, which must be submitted to this department or its designated agent by May 15, 1998. The sanitary issues contained in this plan shall be approved by the Colorado Department of Public Health and Environment or its designated agent. The plan shall be based on, but not limited to, the following criteria:
 - A. Person(s) responsible for and procedures for notification of the state or local health dept. and the public through the news media, as appropriate, when the water quality is out of compliance with section 1 above,
 - B. Number and location of additional bacteriological samples due to size of area.
 - C. Public information on water quality and associated risks, proper hygiene, steps the swimmers can take to reduce their risk, and the steps' swimmers should take to report any illness they believe that they had contracted from the swimming area,
 - D. Minimum number and location of toilet facilities (see appendix E).
 - E. Control of diaper wearing individuals and changing stations.
 - F. Control of pets,
 - G. Voluntary closure when water quality may exceed the standards,
 - H. Maximum bather loads,
 - I. Lifeguards and other personnel,
 - J. Personnel qualifications and training.
 - K. Control of inlet water or other practices to affect water quality,
 - L. Use of sanitary surveys for closing portions of the area due to presence of bacteria,
 - M. Maintenance of reports of health complaints.
 - N. Maintenance of analytical costs.

4.7 CHEMICAL QUALITY:

1. All public pools or semi-public pools shall be automatically and continuously disinfected by a chemical or process which imparts an easily measured residual which complies in all

respects with the Standards of the National Sanitation Foundation (February 1, 1993) covering such chemicals or process.

2. Chemicals used for algae control shall be approved by the Colorado Department of Health.
3. Other disinfecting equipment or materials may be used if they have been adequately demonstrated to the Colorado Department of Health or its authorized agents to provide a satisfactory residual effect which is easily measured or where demonstration and analysis provide assurance that results are otherwise equally effective under conditions of use as the chlorine concentration required herein, and not be dangerous to public health, create objectionable physiological effects or impart toxic properties to water.
4. Any pool shall be immediately closed under the following conditions:
 - A. Disinfection level falls below minimum requirement.
 - B. pH falls below minimum requirement, or exceeds maximum requirement.
5. Table 1 lists the chemical parameters required for any public pool or semi-public pool.

SECTION 4.7
TABLE 1

PARAMETER	REQUIRED PPM		IDEAL PPM	
	Min	Max	Min	Max
Free Chlorine (pool)(DPD method)	0.25***	5.0	1.0	3.0
Free Chlorine (spa, therapy pool (DPD))	.025***	5.0	3.0	5.0
Combined Chlorine	0.00	1.0	0.0	0.0
Bromine (pool)	1.5	5.0	2.0	3.0
Bromine (Spa, therapy, pool)(DPD)	2.0	10.0	3.0	5.0
Total Alkalinity (CaCO ₃)	70	180		
Ph	7.2	8.0	****	7.6
Calcium Hardness	150	600	7.4	400
			200	
Temperature (incl. Spas, therapy pools)	77	104	****	****
O.R.P.(in mv) (if applicable)*	250	900	650	850
Hydrogen Peroxide	20	100	30	40
Ion Generator (if applicable)**			0.3	
Copper	0.25	0.95	25	0.5
Silver	15	50	25	40
Ozone (supplemental oxidizer only)	N/A	0.1	N/A	N/A
Saturation Index (Langlier Index)	-0.5	+0.5	-0.2	+0.2
Cyanuric Acid (ppm)	20	100	20	40

* O.R.P at a pH of 7.5, and in accordance with Graph #1.

** In conjunction with a 0.4 ppm chlorine residual.

*** 0.25 ppm chlorine residual only when used with an approved supplemental oxidizer.

**** Differences may occur according to pool finish, disinfectant, etc. Consult your pool manufacturers recommendations for ideal level.

***** Recommended general use swimming pool temperature range + 82-84 degrees F.

GRAPH #1 FREE CHLORINE PPM

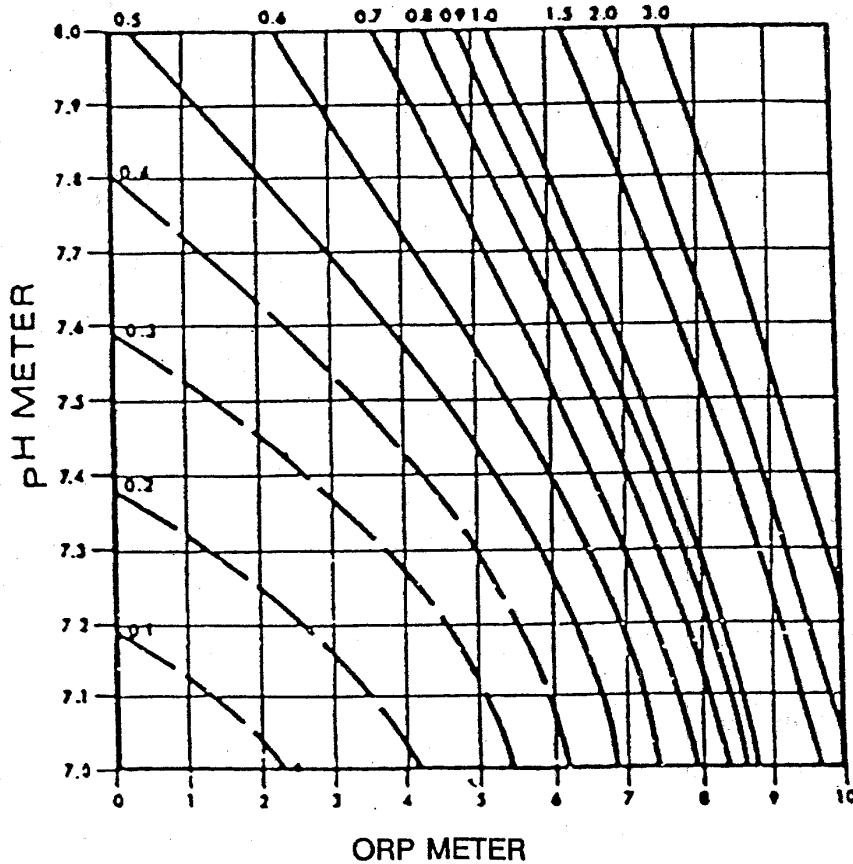

4.8 TURBIDITY:

1. The water shall have sufficient clarity at all times so that the grate openings on the maindrain are clearly visible from the deck. Failure to meet this requirement shall constitute grounds for immediate closing of the pool.
2. No algae or foreign matter shall be present in the pool water.

4.9 SWIMMING POOL AND SPA/HOT TUB OPERATION:

The owner or operator of each public pool or semi-public pool shall have on staff or under contract for each facility a current Certified Pool Operator* (CPO) (*National Swimming Pool Foundation Certification), an Aquatic Facility Operator* (AFO) (*National Recreation and Parks Association Certification), or an NSPI Tech I (*National Spa and Pool Institute Certification Program) or other approved certification program. All public pools or semi-public pools shall maintain a record of information regarding operations of the pool. Included within this record shall

be, but not limited to, disinfectant levels, pH, calcium hardness levels, total alkalinity, flow meter readings, temperatures, pool balance calculations, SCBA or canister-type respirator checks, gas canister expiration dates, and maintenance procedures. The following schedule sets forth the frequency at which specific parameters of pool operation shall be recorded in the pool record:

At least one (1) of the daily pool chemistry readings must be taken manually (not from an electronic readout). It is preferred that this be the first reading of the day.

*Swimming Pools (Includes therapeutic pools and wading pools)

3/Times/Day	Daily	Weekly	Monthly
Disinfectant Level	Flowmeter Reading	Cyanuric Acid	SCBA or
PH	Temperature		Canister Type Respirator
Date	Saturation Index		check
ORP	Calcium Hardness		Respirator Canister expiration
	Total Alkalinity		
	Maintenance		
	Procedures		

*Spa/Hot Tub

2 Hour Intervals	Daily	Weekly	Monthly
Disinfectant Level	Flowmeter Reading	Cyanuric Acid	SCBA or
PH	Saturation Index		Canister type respirator check
Temperature	Calcium hardness		Respirator canister expiration
	Total Alkalinity		
	Maintenance		
	Procedures		

- To check the balance of the pool: pH, temperature, calcium hardness and total alkalinity must be checked simultaneously.

The record of the pool operations shall be kept at the facility and shall be available for inspection by anyone upon request.

The pumps, filters, disinfectant units, chemical feeders, heaters, and related appurtenances shall be kept in operation at all times that the swimming pool is in use and for each additional period as needed to keep the pool in compliance with these regulations. Recirculation equipment shall provide a minimum turn over of swimming pool water every six (6) hours, therapeutic pool water every four (4) hours, separate wading pool water every one (1) hour, and spa/hot tub water every thirty (30) minutes. All equipment shall be maintained in good working order. Floating scum, sputum or debris shall not be allowed to accumulate in the pool.

4.10 HEATING AND VENTILATION

1. Bath houses, indoor dressing rooms, shower rooms, and toilet rooms shall be properly ventilated. Ventilation of indoor swimming pools shall be so designed that bathers will not be subjected to drafts.

2. All heating units and electrical outlets shall be isolated or protected from contact by bathers to prevent injuries.

4.11 BATHER CONTROL:

1. All bathers, before entering the swimming pool, shall be required to take a cleansing shower bath, using warm water and soap and rinsing off all soap before entering the pool. Soap shall be provided by the facility.
2. Persons having any considerable area of exposed sub-epidermal tissue, cuts, or known or recognizable contagious diseases, shall not be permitted to use the pool. Therapy pools used exclusively for prescribed treatments are exempt from this sub-paragraph 2, and shall be closed to the public during treatment times.
3. Spitting, or blowing the nose in the pool shall be strictly prohibited.
4. If towels, bathing suits, combs, brushes, or any other such articles are furnished by the pool management, they shall be clean at the time of issue to the patron and shall have been cleaned and sanitized in a manner acceptable to the health department.
5. The bather load shall not be permitted to exceed the design limitation as determined in Section 3.23. Such limitation shall be posted at facility.

4.12 WASTE DISPOSAL:

The sewer system shall be adequate to serve the facility, including bathhouse, locker room and related accommodations. The sewer line serving the backwash for the filter shall be 1-1/2 times the size of the backwash line or provide a containment vessel capable of holding a minimum of 5 minutes volume of backwash water at the backwash design rate.

There shall be no direct physical connection between the sewer system and any drain from the swimming pool or recirculation system. Any swimming pool, gutter drain, overflow from the recirculation system when discharged to the sewer system shall connect through a suitable air gap so as to preclude the possibility of backflow sewage or waste into the swimming pool piping system.

The sanitary sewer serving the swimming pool and auxiliary facilities shall discharge to the public sewer system wherever possible. Where no such sewer is available, the method of disposal shall be in accordance with the requirements of the Colorado Department of Health or local health department.

4.13 RIGHT OF ENTRY:

All swimming areas shall be open to inspection and water sample collection at any time they are in use, and at any other reasonable time, by agents of the Department of Health.

4.14 DISEASE CONTROL:

1. Any person with a communicable disease, that is transmittable by water shall not be permitted to use the pool facilities.
2. Hospital therapy pools shall maintain adequate water disinfection to protect users from communicable diseases.
3. Should feces be found in the pool at any time, the following procedure shall be followed:
 - A. Pool shall be closed and all bathers removed.
 - B. Solid matter shall be removed.
 - C. Water chemistry shall be checked.
 - (1) If disinfection levels are within required parameters, the pool shall remain closed for at least 60 minutes and then re-opened.
 - (2) If disinfection levels are not within the required parameters, the pool shall be closed and the disinfection level restored. The pool may re-open 60 minutes after acceptable disinfectant levels have been attained.
 - D. If feces are in the form of diarrhea, the pool shall be closed, superchlorinated (or equivalent), remain closed for 24 hours, and then re-opened if disinfection levels are within required parameters.

4.15 FACILITIES TO BE KEPT CLEAN AND IN GOOD REPAIR:

All shower rooms, dressing rooms, equipment rooms and appurtenant facilities shall be kept clean at all times. Daily hosing down of all facilities is required. Disinfection of public areas is required daily or more frequently as needed.

Animals shall not be permitted in pool or pool area, except patrol dogs accompanying security or police officers, or guide dogs and service dogs accompanying blind, visually handicapped, deaf, partially deaf and otherwise physically disabled persons.

All parts of the pool and related pool facilities and equipment shall be maintained in good repair. Floors shall be kept free from cracks and other defects. Walls, ceilings, partitions, doors, lockers and similar surfaces and equipment shall be finished in a manner acceptable to the health department and refinished as often as necessary to be kept in good repair.

Injunctive Relief: (25-5-807 CRS)

The operation of a swimming area in violation of any provision of these regulations may be restrained by the director of the Colorado Department of Health, by any city, county, city and county, or district health officer, or by any of their authorized agents in an action brought in court of competent jurisdiction pursuant to the Colorado rules of civil procedures.

ARTICLE V

PUBLIC BATH

1. The water supplied for any public bath facility shall be maintained free of disease causing organisms and shall be provided under one of the following conditions:
 - A. The water shall be recirculated in accordance with the specifications in Section 3.10, and shall meet the disinfection requirements of Section 4.7, or
 - B. The water shall be exchanged by flow-through of unused water so as to provide a complete change of water in one (1) hour or less if the basin capacity is less than one thousand (1000) gallons; or in two (2) hours or less if the basin has a capacity greater than one thousand (1000) gallons, or
 - C. The use of a combination of (A) and (B) above, in any manner such that the water shall meet the bacteriological requirements of Section 4.6, based on not less than five (5) samples equally spaced over each thirty (30) day period during operation, or
 - D. The water shall be used exclusively by one person, after which the basin shall be drained. The basin shall be cleaned and sanitized between uses. The water shall contain at least a 0.25 part per million chlorine residual (or other comparable residual) at all times.
2. The interior surfaces of the basin shall be clean and kept in good repair.
3. Toilet facilities shall comply with Section 3.21 of these regulations. They shall be of cleanable, impervious construction; kept in good repair; and kept clean.
4. Shower facilities shall comply with Section 3.22 of these regulations, unless individual facilities are provided for each bath unit. They shall be of cleanable, impervious construction; kept in good repair; and kept clean. Each person shall shower in compliance with Section 4.11(1) of these regulations prior to entering the bath water, unless the bath is an individual bath.
5. Dressing rooms, when provided, shall comply with Section 3.20 of these regulations. They shall be of cleanable, impervious construction; kept in good repair; and kept clean. Resting rooms or reclining facilities shall be of cleanable, impervious construction; kept in good repair; and kept clean.
6. Potable drinking water shall be supplied to the premises and shall meet the Colorado Primary Drinking Water Regulations, 5 C.C.R. 1003-1.
7. The sewer system serving the facility shall comply with Section 4.12 of these regulations.
8. All appurtenances to the bath facility shall be of cleanable construction; kept in good repair; and kept clean.

STATE OF COLORADO

Bill Owens, Governor
Douglas H. Benevento, Executive Director

Dedicated to protecting and improving the health and environment of the people of Colorado

4300 Cherry Creek Dr. S. Laboratory Services Division
Denver, Colorado 80246-1530 8100 Lowry Blvd.
Phone (303) 692-2000 Denver, Colorado 80230-6928
TDD Line (303) 691-7700 (303) 692-3090
Located in Glendale, Colorado
<http://www.cdphe.state.co.us>



Colorado Department
of Public Health
and Environment

NOTE: Although Appendix A is not part of the official Regulations Pertaining to Swimming Pools and Mineral Baths, 5 CCR 1005-3, as adopted by the State Board of Health and published in the Code of Colorado Regulations, it is included for the convenience of the user in this unofficial version of the regulations published by the department.

APPENDIX A REQUEST FOR DESIGN REVIEW

Date: _____

Name of Pool:	_____	Phone:	_____
Address: _____			
Name of Owner:	_____	Phone:	_____
Address: _____			
Name of Builder:	_____	Phone:	_____
Address: _____			

General Information:

Length: _____ Width: _____ Shape: _____

Construction: _____ DEPTH Minimum: _____ Maximum: _____

Capacity _____ gals. Surface Area _____ sq. ft. Bather Load _____

Spa/Hottub:
Capacity _____ gals. Surface Area _____ sq. ft. Construction _____

Decks:

Size: _____ Construction _____ Finish _____ Slope _____

Drains provided? _____ Type _____ Location _____

Hose bibs provided? _____ Fencing (describe) _____

Depth Markers Provided: Pool wall _____ Deck _____ Letter size _____

Water Supply:

Source: _____ Fill Spouts: _____ Location: _____ Slope _____

Air gap provided on fill spout? _____

Waste disposal:

Backwash water to sanitary sewer _____ Indirect Connection: _____

Sightglass provided? _____ Location _____

Other? _____

Equipment:

Main Drain:
 Number: _____ Size: _____ Pipe Size: _____ Grating: _____

Skimmers: One per 500 sq. ft. of surface area. Minimum of two. Number _____ Size: _____

Make: _____ Model: _____ Equalizer line provided? _____

Overflow gutters (if used): Surge tank provided? _____ Outlet pipe Size _____

Distance between outlets _____ Make _____ Model _____

Inlets: Number _____ Discharge depth _____ Distance between inlets _____

Pumps:

Pool	Make	Model	HP	Capacity (GPM@60Tdh)
Wading pool				
Spa/Hot Tub				
Other				

Filters:

Pool	Make	Model	HP	Capacity (gpm)
Wading pool				
Spa/Hot Tub				
Other				

Flow gauge provided: _____ Located: _____

Pressure gauge(s) provided; _____ Suction cleaning provided: _____

Heater:

Pool	Make	Model	HP	BTU
Wading pool				
Spa/Hot Tub				
Other				

Electrical GFI 's: Mechanical room _____ Bath/dressing rooms _____ Pool Complex _____

Disinfection System:

Chlorine _____ Bromine _____ Other _____ Grating _____

Equipment: Make: _____ Model: _____ Type Gas _____ Erosion _____ Hypo _____

Gas System: Separate room _____ 1-foot window in door _____ Gas mask _____

Exhaust vent within 6 inches of floor level _____ Intake located near ceiling _____

Exhaust fan automatically activated: _____

How? _____

Leakage test kit _____ Safety brackets _____

Hypo systems: Regulator provided _____ Backflow/back siphonage features _____

Other Equipment;

Diving boards: Number _____ Water depth _____ Board Height _____ Headroom _____ Horizontal Separation _____

Lights: Number _____ Make _____ Model _____ Watts _____

Ladders provided _____ Location _____ Steps _____

Lifesaving equipment _____ Safety line _____

Other: _____

Bathouse Facilities

Floors (Construction)	Showers	Toilet rooms	Dressing rooms
Walls (Constructiion)			
Ceilings (Construction)			
Drainage			
Ventilation			

Fixtures:

Male	Showers	Toilet rooms	Dressing rooms
Female			

Turnover rates: Pool _____ Wading Pool _____
 Spa/ _____ Other _____
 Hot tub _____

Additional
 Comments: _____

Appendix B: Biological Standard for Natural Swimming Areas
(Escherichia Coliform as Initial Test)

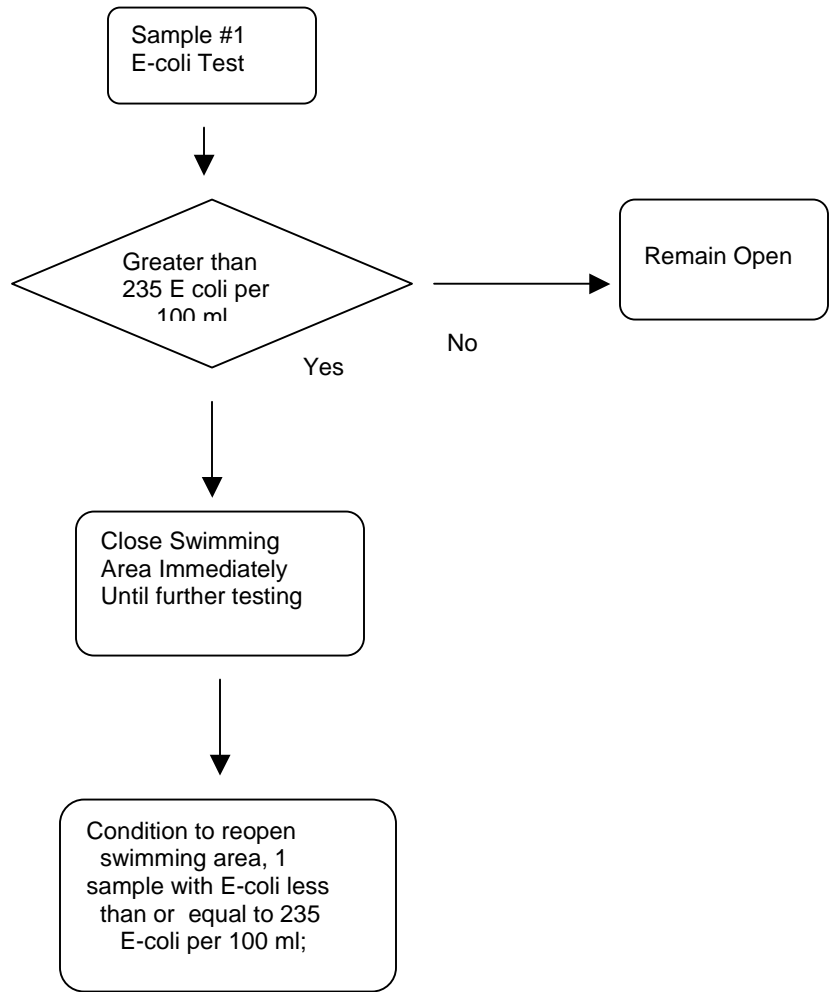

Appendix C: Biological Standard for Natural Swimming Areas who have entered into a Memorandum of Agreement

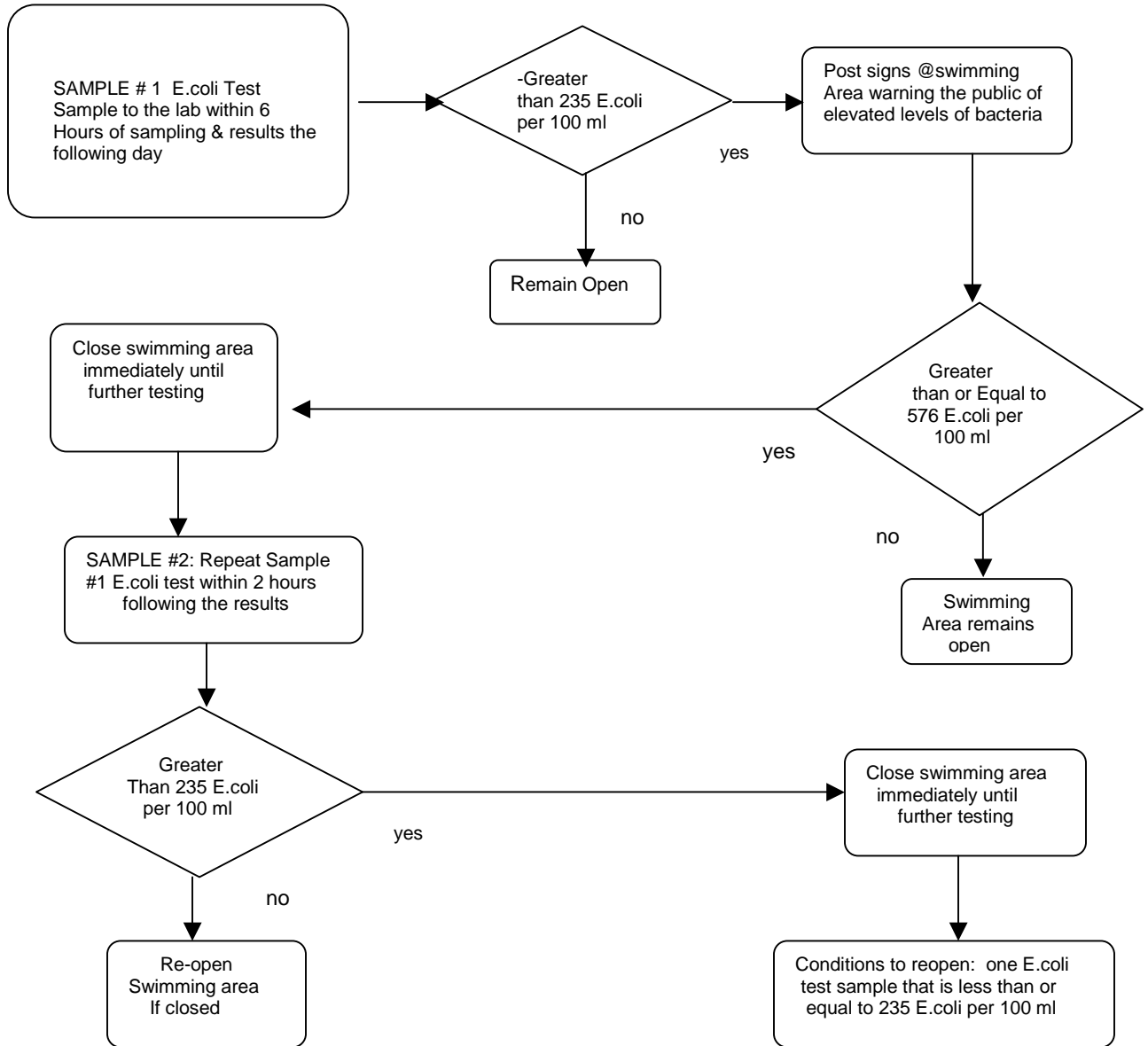

Appendix D
SAMPLING PROTOCOL
FOR
NATURAL BATHING BEACHES

I. PERSONAL SAFETY AND CLEANLINESS

Good personal safety and cleanliness goes a long way for promoting aseptic sampling. The following measures help to prevent the sampler from becoming part of the sample.

1. Wash hands with a bactericidal soap and water BEFORE and AFTER sampling.
2. Keep all food and drink away from sampling sites, sampling equipment and sample containers.

II. SAMPLING METHOD

1. Determine where the samples are to be collected.
 - Collect one sample for approximately every 50 meters of beach. Take the first sample near the middle of the beach and then proceed 50 meters in each direction down the beach to collect each subsequent sample.
 - Collect samples(s) near the beach where swimmers could be exposed to contaminated water entering the lake/reservoir (e.g., storm water drains, natural contours which drain rest room or septic system areas, etc).
2. Collect samples during greatest bather load (i.e., peak usage time). Allow enough time to collect the sample and have it properly shipped or delivered to a lab for analysis. Please be aware that the sample **MUST** be received by a lab and the analysis begun within 30 hours of collection.
3. Obtain one PRE-STERILIZED sample container for each sample site. Do Not open the container until you are ready to collect the sample. The sample may either be hand collected or a sampling device may be used.
4. Label each container with a water proof marker with the following information: date and clock time of collection, sample location (could be a predetermined ID number specific for each sampling site), and sample number (typically provided by the lab). Complete a Sample Collection Form For Multiple Sampling Sites (again, provided by the lab).
5. Follow the Personal Safety and Cleanliness instructions above. If a sampling device is used, wipe the entire surface of the device with a fresh alcohol swab – allow device to dry before sampling.
6. At each sampling site, wade out into the water far enough so the sample can be collected from where the water is approximately 3 feet deep. Disturb the bottom sediment as little as possible.
7. Open sample container. Be careful not to touch the inside of the container (or lid if present). **DO NOT RINSE** the container.

8. Collect the sample facing into the wind or current. Make every effort to collect as little disturbed sediment as possible (high levels of turbidity will interfere with the test method).
- 9a. Hand Sampling – Grasp sample container near the base, invert, and plunge into the water to a depth of approximately 12 inches. Slightly tilt the container into the wind or current and push forward horizontally away from your hand and body to fill. Avoid contact with the bank or bed. Remove container upright and vertically from the water.
- 9b. Sampling Device – Follow the directions for collection with a sampling device specific for the device.
10. The sample container should be nearly full when it is removed from the water. Pour out some of the sample so the water level is just ABOVE the 100 ml line on the container (about ½ inch of head space in the container is necessary mixing the sample in the lab).
11. Without touching the inside of the container or lid, secure the container shut. Check the container for leakage.
12. When hand sampling, change gloves before collecting another sample. When using a sampling device, wipe the entire surface with a new alcohol swab before collecting another sample.
13. Pack the sample(s) for shipment or delivery to the lab. Ideally, the sample(s) should be shipped with ice (or a frozen gel ice pack) to keep the sample(s) cool during shipment. Be sure to include the sample collection form.

Appendix E: Guidelines for Restroom Facilities

Toilet facilities for the use of swimmers shall be provided for both males and females and shall be accessible to disabled persons.

The required number of toilets can be determined in the following methods:

- a) use the toilet section of Article 3 of these regulations for permanent facilities, or
- b) use the filling table, or

Peak Crowd	Average time at event (Hours)									
	1	2	3	4	5	6	7	8	9	10
250	2	2	2	2	2	3	3	3	3	3
500	2	3	4	4	4	4	4	4	4	4
1000	4	5	6	7	7	8	8	8	8	8
2000	6	10	12	13	14	14	14	15	15	15
3000	9	14	17	19	20	21	21	21	22	22
4000	12	19	23	28	28	30	28	30	30	30
5000	15	23	28	32	34	36	36	36	36	36
6000	17	28	34	38	40	42	42	42	44	44
7000	20	32	40	44	46	48	50	50	50	50
8000	23	38	46	50	54	57	57	57	57	57
10000	30	46	57	63	66	69	69	72	72	72

- c) use a combination of (a) and (b) above.

There are many instances when portable sanitation units are necessary to accommodate the need for restroom facilities. Under normal conditions, the average individual uses sanitary facilities once every four hours. The consumption of food, beverages, and alcohol will increase this usage by 30-40%. The above table assumes that the average time between uses is 2 hours.